

APPLICATIONS

Lifting by the flange of I or H profiles; fabricated assemblies, plates in horizontal position.

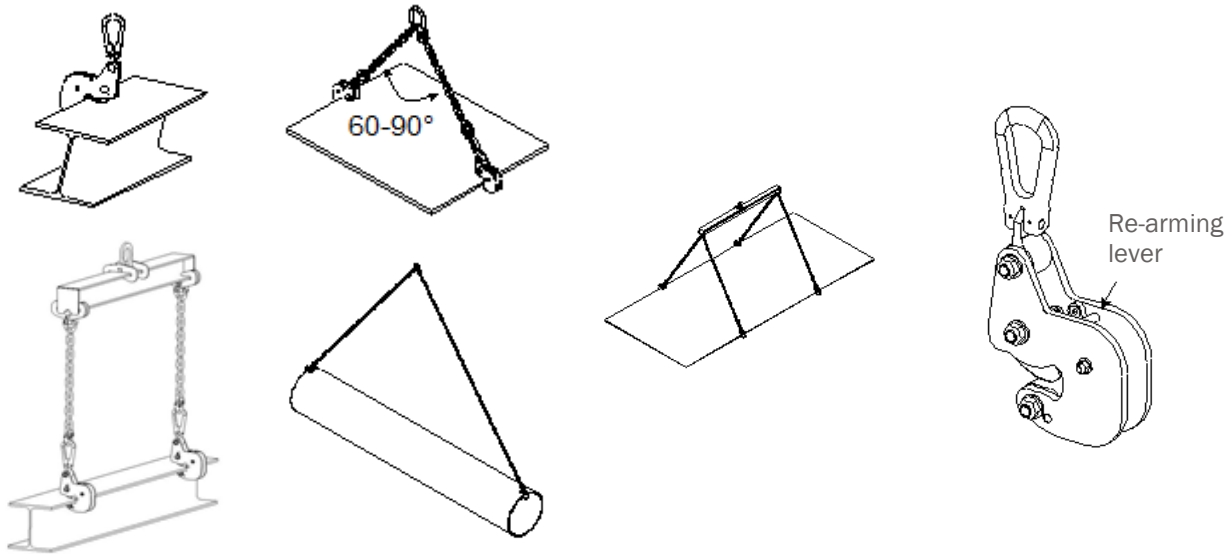

DESCRIPTION

Clamp fitted with a safety spring mechanism allowing permanent contact of the cam on the load to be lifted, even when it is being laid down. This model is also equipped with an automatic grasping ensuring the clamp's closing when the plate or profile is positioned at the back of the clamp's throat. The locking lever does not stick out so that it cannot be damaged. The corrugated cam only marks one side of the load.

FUNCTIONING

So as to open the clamp's cam, push the lever situated on top between the 2 flanges until the trigger activates; the clamp thus locks itself in the open position. When the load is driven home into the clamp's throat, the trigger activates and the clamp closes automatically.

The corrugated cam penetrates the load's material. Lifting ensures proportional clamping. To release the clamp, push the lever downwards. The clamp may also be used without the automatism being activated. To do so, use the manual opening and closing thanks to the lever without bringing it to its limit stop (trigger not activated).

Use in pairs (with a lifting beam in case of several pairs) and 2-legged sling(s) for handling horizontal plates.

GENERAL CHARACTERISTICS

- Manufactured without load bearing welds.
- Hot epoxy coating.
- Safety factor: 3 in accordance with the EN 13155.2003 norm.
- Product conforms to the French regulation, in particular the decree of 01/03/2004 relating to the check on lifting devices and the European Directive n°98/37.
- Product with EC marking and delivered with a declaration of conformity and instructions for use.

IMPORTANT INSTRUCTIONS

- The plate or piece to be lifted must always be driven home into the throat of the clamp.
- Load maximum surface hardness: 330 HB and minimum tensile strength 20 daN/ mm².
- Some stainless steels are particularly abrasive; closely check the condition of the cam's teeth in this case.
- For safety's sake, ensure the clamps are always unlocked when not in use (closed cam).
- Never lift more than one plate/ girder at a time.
- Apply the downgrading if necessary.
- Recommended sling angle when lifting horizontal plates: 60 to 90°.
- The minimum weight of lifting load should be equal to 5% of the clamp's WLL (e.g. if clamps WLL is 1000 kg, then minimum weight is 50 kg). This value is given for a clamp in perfect working order and respecting Tractel Solutions SAS conditions of use and recommendations. Consult Tractel in case of loads with weight inferior to the minimum recommended value.
- Lifting clamps are not suitable for creating permanent joints.
- Working temperature: -20° to +100°C.

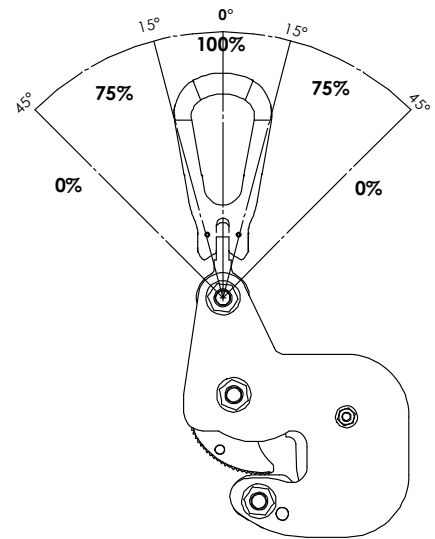

DIMENSIONAL CHARACTERISTICS

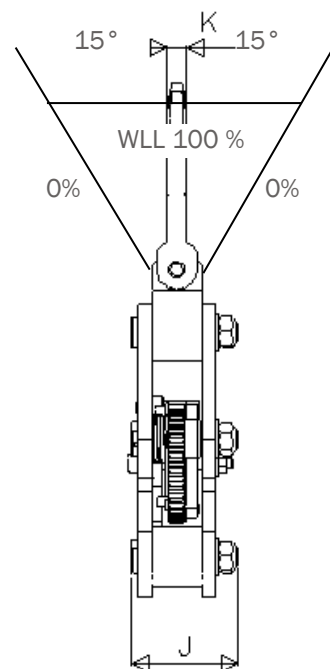
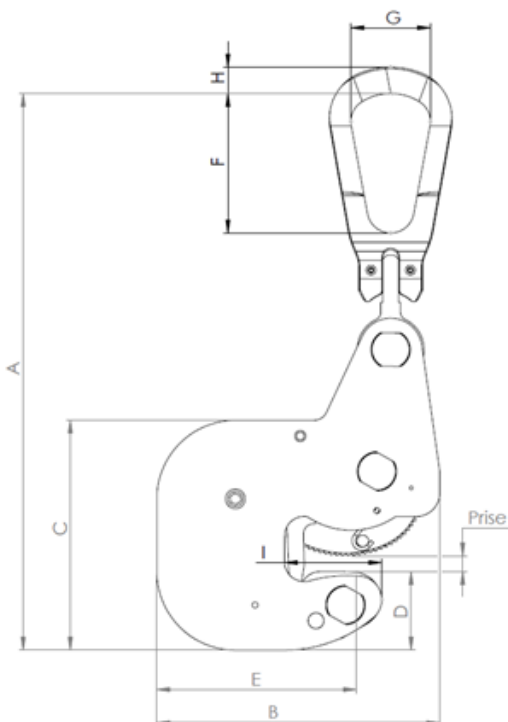

Never exceed
the allowed 15°
angle between
the ring and the
flanges

Ref.	Group code	WLL kg	Opening		A	B	C	D	F	G	H	I	J	K	Weight kg
			min	max											
KP1 0-20	50218	1 500	0	20	283	144	120	40	71	40,5	13,5	49,5	62	11	4
KP2 0-30	50228	3 000	0	30	417	214	185	62	115	66	22	75,9	92	20,5	10

Dimensions in mm